

Accessing IV ports: improving efficiency

Dennis Fitzpatrick, University of West London; **Andrew Barton**, Frimley Park Hospital, and **Keith Pamment**, City University, London, discuss a port location device that has been designed to improve first attempt port access, and to minimise the risk of subcutaneous infection and pain that a patient experiences with subsequent needle insertion attempts.

In today's Healthcare environment, Intravenous (IV) therapy is routinely used for the treatment of chronic conditions such as cancer, cystic fibrosis, sickle cell disease, Haemophilia and immunological disorders. The delivery of drugs, infusions, coagulation factors and antibiotics into the body is administered via implanted venous access ports (VAPs) also known as intravenous (IV) ports. These ports have a catheter that is surgically inserted directly into a vein, thus providing a more efficient delivery of medication into the body. Using a port, there is one access site for medication administration compared to locating alternative suitable sites for regular hypodermic needle injections.

A port typically consists of a metal, porcelain or plastic chamber that acts as a reservoir for the medication and a catheter connected to a port outlet. The top of the chamber is known as the septum and consists of a membrane of self-sealing silicon rubber. The ports are implanted subcutaneously such that the top of the port chamber is seen as a 'bump' under the skin. A non-coring needle such as a Huber needle is then inserted through the skin into the centre of the chamber in order to deliver the medication.

Inserting a non-coring needle through the skin into the centre of the port septum does require a certain amount of skill. The port is held in place after feeling around for the underlying rim of the port and then effectively 'best guessing' the centre of the port for needle insertion with the other hand.

Being able to clearly see the site for needle insertion does help raise the confidence level for a more central needle insertion into the centre of the port septum.



Figure 1: Misaligned needle insertion resulting in a) Port failure split in the casing and b) Needle insertion scratches against the port casing.

The port can be held securely in place using three fingers but this does obstruct the view of the centre of the skin bump, making it difficult to site the needle for insertion into the centre of the septum. Experienced users can hold the port in place using two fingers, but the port is not held as securely in place compared to using three fingers. Other factors that determine port access includes port location and subcutaneous depth.

Port access also requires a significant amount of confidence in accessing the port first time and can cause concerns amongst health professionals when accessing or providing maintenance and care of the port.¹ Unsuccessful port access by unskilled or less confident health care professional can also cause anxiety for patients.² Repeated attempts (stabs) can also be painful for the patient, can cause bleeding and increase the

risk of infection in the subcutaneous tissue.³ This was especially the case for cystic fibrosis patients who experienced difficulty in holding their ports firmly in place while simultaneously inserting the needle into the centre of the port. In one particular case, a malfunctioning port, surgically removed was found to have a crack in the casing as seen in Figure 1a. On closer inspection, the port septum showed a non-central grouping of needle insertion points towards the port casing. Figure 1b shows the respective needle scratches against the port casing due to misaligned needle insertions that may have attributed to the port failure.

The experience of cystic fibrosis patients and healthcare staff led to the development of the Portacator by DenKe Medical in a bid to help increase the success rate of accessing the port chamber on the first attempt. The Portacator can locate and securely hold the port in place using two fingers allowing for an unobstructed view of the port profile for a more confident needle insertion towards the centre of the port chamber (see Figure 2). Once the needle is in place, the two flanges of the device are pulled apart enabling it to slide away without disrupting the needle placement. ►

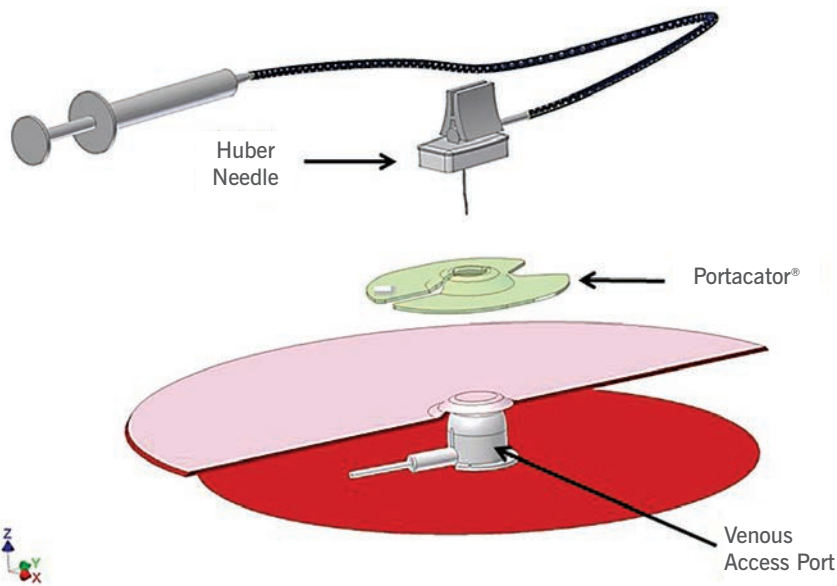

Figure 2: The device holds the port securely in place and emphasises the port profile to enable a more confident central needle insertion into the port chamber.

Figure 3 shows that the port profile is clearly defined using the Portacator. Only two fingers are used to hold the port securely in place allowing for an unobstructed view of the area of the skin covering the port. Being able to clearly see the site for needle insertion does help raise the confidence level for a more central needle insertion into the centre of the port septum.

When the non-coring needle is pushed into place, the device is removed by gently pulling the two flanges apart and sliding it away as shown in Figure 4.

The performance was evaluated using a custom port rig that simulates port movement in subcutaneous tissue when locating and accessing the port chamber with a non-coring needle, such as a Huber needle. A clinical study was also performed by staff in two NHS Clinical Units at Frimley Park NHS Trust.⁴

Port test rig

The Port Rig is a custom built unit that consists of a port, a synthetic skin covering to simulate skin and subcutaneous tissue and a movement mechanism that simulates port movement during location and access. Needle insertion points through the rubber skin of the port's septum, are recorded by a miniature camera placed in the port chamber.

Subjects were asked to access the port using a non-coring needle without and then with the Portacator. The results showed that there was a closer distribution of the needle insertion points towards the centre of the port when using the latter. There were some cases in which the needle missed the port completely. Subjects also reported that they were more confident in accessing the centre of the port's septum when using the device.

Figure 6 compares the recorded needle insertion points through the port membrane into the Port chamber without the Portacator

(Figure 3a) and with the Portacator (Figure 3b). Using the device there is a consistent grouping of needle insertion points through the membrane into the Port chamber. Figure 3a shows a wider distribution of needle insertion points and in two instances, the inserted needle completely missed the Port chamber.

Clinical study

Staff in the medical day unit and intravenous therapy day unit at Frimley Park NHS Trust evaluated the device on 11 outpatients from each unit over a period of 13 weeks. All patients have their ports accessed routinely on a weekly, two weekly or monthly basis to administer treatment or to flush their port. Both day units support patients with VAPs that require regular IV therapy infusions for long term chronic illness. Vascular access



Figure 3: The device clearly defines the port profile and site for central needle insertion.



Figure 4: The Portacator is removed by pulling the two flanges apart and sliding it away.

specialists when requested, provide support for staff that are less confident in accessing patient's Ports to administer treatment and port flushing. The success rate of using the Portacator was determined by first attempt access to the port. This also gives a measure of not only the staff's confidence level but also the patient's confidence level knowing that their port will be accessed on the first attempt.

In the medical day unit there was a marked increase in the success rate from 40% to 85% when accessing patients' ports on the first attempt when using the device. In the intravenous therapy day unit, where staff have more experience in accessing patient ports, there was an increase from 75% to 90% in the success rate in accessing patients' ports on the first attempt when using the Portacator. In both day units, the staff commented on the fact that the device provided a more secure

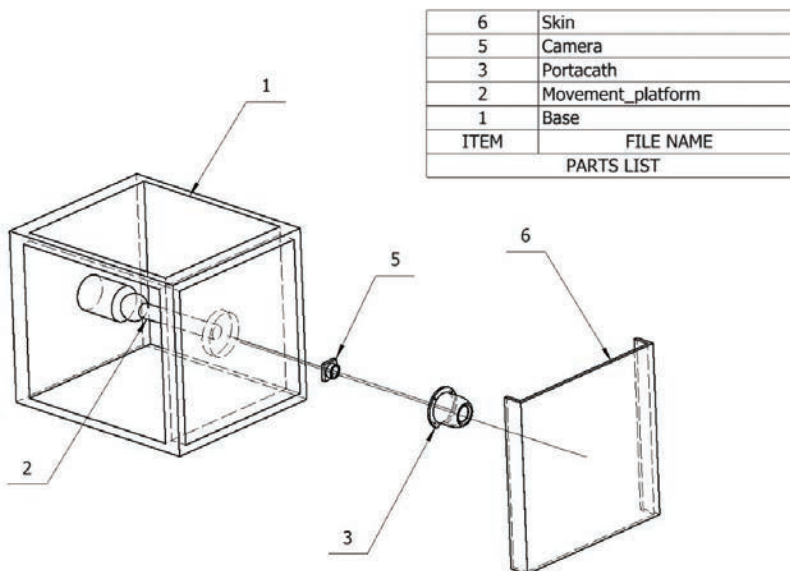

Figure 5: Test Rig to evaluate needle insertion points into the port septum.

Patient no	Port size	IP location	IP use	Previous failures	Successful attempts to access port during 13 weeks													
					1	2	3	4	5	6	7	8	9	10	11	12	13	14
1	9fr	Right UC	IVIG	Yes, past 3 attempts	1st		2nd		1st		1st		1st		1st		1st	
2	9fr	Right UC	IVIG	Yes, past 2 attempts	1st		1st		1st			1st		1st				1st
3	9fr	Left UC	IVIG	Yes, past 4 attempts	2nd			1st		1st		1st		1st			1st	
4	9fr	Right UC	IVAS	No	1st	1st	1st		1st			1st			1st	1st	1st	
5	9fr	Right UC	IVAS	Yes, past 3 attempts	1st	1st	1st		2nd			1st					2nd	
6	9fr	Right UC	IVIG	No	1st			1st			1st			1st				1st
7	9fr	Right UC	MS	Yes, past 3 attempts	1st					1st							1st	
8	9fr	Left UC	MS	Yes, past 1 attempts	1st						1st						1st	
9	9fr	Right UC	Chemo	Yes, past 1 attempts	1st			1st			1st			1st				1st
10	9fr	Left UC	Chemo	No	2nd		1st			1st			1st				1st	
11	9fr	Left UC	Chemo	Yes, past 4 attempts	1st		1st	1st		1st			1st				1st	

Table 1: Number of successful attempts to access a port using the Portacator (Barton *et al*, 2018). (Reprinted with permission).

hold of the port and provided a clearer view of the skin area for needle insertion, thus increasing the confidence of a first attempt port access. All users commented on the ease by which it is removed by separating the two flanges and sliding away without disturbing the needle in-situ. The number of successful attempts to access a port is summarised in Table 1 that clearly shows a first attempt success rate of port access.

Discussion

The results from the port rig clearly showed that a more central grouping of needle insertion points was achieved using the Portacator compared to non-use. Its profile has been designed to sit over the port to hold it securely in place using only two fingers, providing an easy visual reference for central non-coring needle insertion and giving a clear unobstructed view of the skin area over the port into which the needle is inserted.

Using the device also boosted the confidence level of staff and patients when accessing ports during the clinical study. Subsequently it could be incorporated into training programmes to enhance staff skills to efficiently access ports, and also for staff to train patients to have confidence in accessing their own ports and to self-medicate. The training could be extended to healthcare workers and carers in the wider community to help patients access their ports at home and subsequently reduce the number of out-patients visits to specialist clinical units.

The device clearly improves the accuracy of needle insertion into the centre of venous access ports and also increases the confidence levels for staff and patients in accessing ports on the first attempt. This also minimises the complications associated with repeated attempts, such as tissue infection,

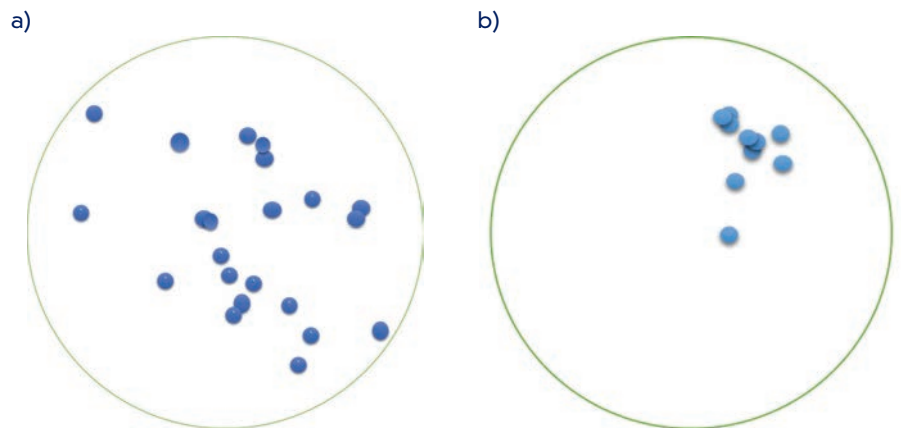

Figure 6: Needle insertion points into the rig port chamber. a) Without using the Portacator (3.15mm ±1.051). b) Using the Portacator (1.87mm ±1.121). 1= mean ± SD. 10mm diameter.

haematomas and a painful experience for the patient. Frimley Park Hospital staff in the specialist vascular access clinics have adopted the Portacator as the preferred method to access patients’ ports, especially as it is now available individually or within a Port IV Access Pack that can be purchased from pfm medical.

CSJ

References

- 1 Dougherty L, 2011 Implanted ports: benefits, challenges and guidance for use *British Journal of Nursing* 20 4: S12–S19
- 2 Bow EJ, Kilpatrick MG, Clinch JJ. Totally implantable venous access ports systems for patients receiving chemotherapy for solid tissue malignancies: a randomized controlled clinical trial examining the safety, efficacy, costs, and impact on quality of life. *J Clin Oncol.* 1999; 17 4:1267. <https://doi.org/10.1200/JCO.1999.17.1267>
- 3 Zaghaf A, Khalife M, Mukherji D, El Majzoub N, Shamseddine A, Hoballah J, Marangoni G, Faraj W,

- 2012 Update on totally implantable venous access devices *Surgical oncology* 21 3: 207-215
- 4 *British Journal of Nursing*, 2018 (IV Therapy Supplement), Vol 27, No 19: S20-S24. Evaluation of a device to improve non-coring needle insertion into implanted intravenous ports. Andrew Barton, Keith Pamment, Dennis Fitzpatrick. [doi:https://doi.org/10.12968/bjon.2018.27.19.S20](https://doi.org/10.12968/bjon.2018.27.19.S20)

About the authors

Dennis Fitzpatrick, biomedical engineering research, University of West London.
Andrew Barton, advanced nurse practitioner vascular access & IV therapy lead, Frimley Park Hospital.
Keith Pamment, senior research technician, City University, London.